

#### LCX Liquid Cooled Adjustable Frequency Drives

2



#### Contents

##### Description

Page

LCX Drives	
Catalog Number Selection	<b>V6-T2-393</b>
Product Selection	<b>V6-T2-394</b>
Options	<b>V6-T2-397</b>
Technical Data and Specifications	<b>V6-T2-398</b>
Wiring Diagrams	<b>V6-T2-399</b>
Dimensions	<b>V6-T2-401</b>

#### Product Description

The LCX Liquid Cooled Drive family continues Eaton's tradition of providing state-of-the-industry products, by taking advantage of liquid cooling technology in lieu of air-cooling techniques.

The LCX drives are liquid-cooled products that utilize potable water or a water-glycol mixture as a cooling medium.

#### Features and Benefits

- Compact size and low heat transfer rates allow enclosure size to be greatly reduced, which is especially beneficial in UL Type 4X applications
- Design is modular, with control and power modules independent of each other. Connection between power and control modules can be direct or extended via a fiber optic cable
- Same reliable control module and operating system as the SPX air-cooled drives
- CE mark ensures compliance with the Electromagnetic Compatibility Directive (EMC) and the Low Voltage Directive (LVD)
- Reliable drive with over 500,000 hours MTBF based on MIL 217
- Currently supports DeviceNet, PROFIBUS-DP, Modbus RTU and Modbus TCP communication protocols
- Separately mounted line reactor included with AC fed models

#### Standards and Certifications

- UL
- cUL
- CE
- IEC



## Catalog Number Selection

## LCX Liquid Cooled Adjustable Frequency Drives

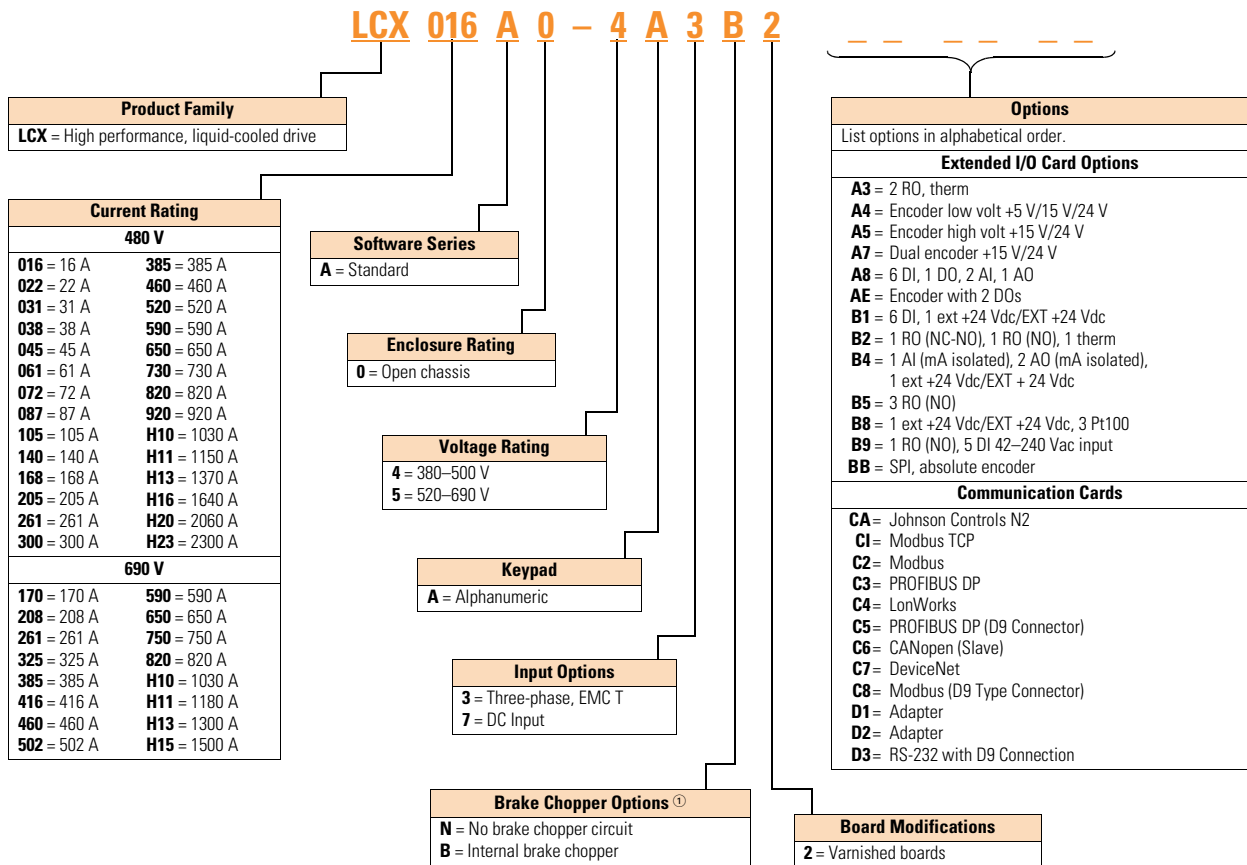
**Note**

① Brake chopper is only available in 480 V CH3 drives.

## Product Selection

2

LCX Liquid Cooled  
Drives

## 380–500 Vac Liquid Cooled Drives

## Motor Output

## Current

Thermal, I <sub>th</sub> (A)	I <sub>L</sub> (A)	I <sub>H</sub> (A)	kW	Chassis	Catalog Number
16	15	11	7.5	CH3	LCX016A0-4A3N2
22	20	15	11	CH3	LCX022A0-4A3N2
31	28	21	15	CH3	LCX031A0-4A3N2
38	35	25	18.5	CH3	LCX038A0-4A3N2
45	41	30	22	CH3	LCX045A0-4A3N2
61	55	41	30	CH3	LCX061A0-4A3N2
72	65	48	37	CH4	LCX072A0-4A3N2
87	79	58	45	CH4	LCX087A0-4A3N2
105	95	70	55	CH4	LCX105A0-4A3N2
140	127	93	75	CH4	LCX140A0-4A3N2
168	153	112	90	CH5	LCX168A0-4A3N2
205	186	137	110	CH5	LCX205A0-4A3N2
261	237	174	132	CH5	LCX261A0-4A3N2
300	273	200	160	CH61	LCX300A0-4A3N2
385	350	257	200	CH61	LCX385A0-4A3N2
460	418	307	250	CH72	LCX460A0-4A3N2
520	473	347	250	CH72	LCX520A0-4A3N2
590	536	393	315	CH72	LCX590A0-4A3N2
650	591	433	355	CH72	LCX650A0-4A3N2
730	664	487	400	CH72	LCX730A0-4A3N2
820	745	547	450	CH63	LCX820A0-4A3N2
920	836	613	500	CH63	LCX920A0-4A3N2
1030	936	687	560	CH63	LCXH10A0-4A3N2
1150	1045	766	600	CH63	LCXH11A0-4A3N2
1370	1245	913	700	CH74	LCXH13A0-4A3N2
1640	1491	1093	900	CH74	LCXH16A0-4A3N2
2060	1873	1373	1100	CH74	LCXH20A0-4A3N2
2300	2091	1533	1200	CH74	LCXH23A0-4A3N2

## LCX Liquid Cooled Drives



## 525–690 Vac Liquid Cooled Drives

## Motor Output

## Current

Thermal, $I_{th}$ (A)	$I_L$ (A)	$I_H$ (A)	kW	Chassis	Catalog Number
170	155	113	110	CH61	LCX170A0-5A3N2
208	189	139	132	CH61	LCX208A0-5A3N2
261	237	174	160	CH72	LCX261A0-5A3N2
325	295	217	200	CH72	LCX325A0-5A3N2
385	350	257	250	CH72	LCX385A0-5A3N2
416	378	277	250	CH72	LCX416A0-5A3N2
460	418	307	300	CH72	LCX460A0-5A3N2
502	456	335	355	CH72	LCX502A0-5A3N2
590	536	393	400	CH63	LCX590A0-5A3N2
650	591	433	450	CH63	LCX650A0-5A3N2
750	682	500	500	CH63	LCX750A0-5A3N2
820	745	547	560	CH74	LCX820A0-5A3N2
920	836	613	650	CH74	LCX920A0-5A3N2
1030	936	687	700	CH74	LCXH10A0-5A3N2
1180	1073	787	800	CH74	LCXH11A0-5A3N2
1300	1182	867	900	CH74	LCXH13A0-5A3N2
1500	1364	1000	1000	CH74	LCXH15A0-5A3N2

## 540–675 Vdc Liquid Cooled Inverter Units

## Drive Output

## Current

Thermal $I_{th}$ (A)	Rated Cont. $I_L$ (A)	Rated Cont. $I_H$ (A)	Motor Output Power		Power Loss c/a/T (kW)	Chassis	Catalog Number
			Optimum Motor at $I_{th}$ 400 V (kW)	Optimum Motor at $I_{th}$ 500 V (kW)			
16	15	11	7.5	11	0.4/0.2/0.6	CH3	LCX016A0-4A7B2
22	20	15	11	15	0.5/0.2/0.7	CH3	LCX022A0-4A7B2
31	28	21	15	18.5	0.7/0.2/0.9	CH3	LCX031A0-4A7B2
38	35	25	18.5	22	0.8/0.2/1.0	CH3	LCX038A0-4A7B2
45	41	30	22	30	1.0/0.3/1.3	CH3	LCX045A0-4A7B2
61	55	41	30	37	1.3/0.3/1.5	CH3	LCX061A0-4A7B2
72	65	48	37	45	1.2/0.3/1.5	CH4	LCX072A0-4A7N2
87	79	58	45	55	1.5/0.3/1.8	CH4	LCX087A0-4A7N2
105	95	70	55	75	1.8/0.3/2.1	CH4	LCX105A0-4A7N2
140	127	93	75	90	2.3/0.3/2.6	CH4	LCX140A0-4A7N2
168	153	112	90	110	2.5/0.3/2.8	CH5	LCX168A0-4A7N2
205	186	137	110	132	3.0/0.4/3.4	CH5	LCX205A0-4A7N2
261	237	174	132	160	4.0/0.4/4.4	CH5	LCX261A0-4A7N2
300	273	200	160	200	4.5/0.4/4.9	CH61	LCX300A0-4A7N2
385	350	257	200	250	5.5/0.5/6.0	CH61	LCX385A0-4A7N2
460	418	307	250	315	5.5/0.5/6.0	CH62	LCX460A0-4A7N2
520	473	347	250	355	6.5/0.5/7.0	CH62	LCX520A0-4A7N2
590	536	393	315	400	7.5/0.6/8.1	CH62	LCX590A0-4A7N2

# 2.12

## Adjustable Frequency Drives

### LCX Liquid Cooled Drives

LCX Liquid Cooled Drives

2



#### 540–675 Vdc Liquid Cooled Inverter Units, continued

##### Drive Output

Current			Motor Output Power		Power Loss c/a/T (kW)	Chassis	Catalog Number
Thermal $I_{th}$ (A)	Rated Cont. $I_L$ (A)	Rated Cont. $I_H$ (A)	Optimum Motor at $I_{th}$ 400 V (kW)	Optimum Motor at $I_{th}$ 500 V (kW)			
650	591	433	355	450	8.5/0.6/9.1	CH62	LCX650A0-4A7N2
730	664	487	400	500	10.0/0.7/10.7	CH62	LCX730A0-4A7N2
820	745	547	450	560	12.5/0.8/13.3	CH63	LCX820A0-4A7N2
920	836	613	500	600	14.4/0.9/15.3	CH63	LCX920A0-4A7N2
1030	936	687	560	700	16.5/1.0/17.5	CH63	LCXH10A0-4A7N2
1150	1045	766	600	750	18.4/1.0/19.5	CH63	LCXH11A0-4A7N2
1370	1245	913	700	900	15.5/1.0/16.5	CH64	LCXH13A0-4A7N2
1640	1491	1093	900	1100	19.5/1.2/20.7	CH64	LCXH16A0-4A7N2
2060	1873	1373	1100	1400	26.5/1.5/28.0	CH64	LCXH20A0-4A7N2
2300	2091	1533	1250	1500	29.6/1.7/31.3	CH64	LCXH23A0-4A7N2
2470	2245	1647	1300	1600	36.0/2.0/38.0	2*CH64	LCXH24A0-4A7N2
2950	2681	1967	1550	1950	39.0/2.4/41.4	2*CH64	LCXH29A0-4A7N2
3710	3372	2473	1950	2450	48.0/2.7/50.7	2*CH64	LCXH37A0-4A7N2
4140	3763	2760	2150	2700	53.0/3.0/66.0	2*CH64	LCXH41A0-4A7N2

#### 710–930 Vdc Liquid Cooled Inverter Unit

##### Drive Output

Current			Motor Output Power		Power Loss c/a/T (kW)	Chassis	Catalog Number
Thermal $I_{th}$ (A)	Rated Cont. $I_L$ (A)	Rated Cont. $I_H$ (A)	Optimum Motor at $I_{th}$ 400 V (kW)	Optimum Motor at $I_{th}$ 500 V (kW)			
170	155	113	110	160	4.5/0.2/4.7	CH61	LCX170A0-5A7N2
208	189	139	132	200	5.5/0.3/5.8	CH61	LCX208A0-5A7N2
261	237	174	160	250	5.5/0.3/5.8	CH61	LCX261A0-5A7N2
325	295	217	200	300	6.5/0.3/6.8	CH62	LCX325A0-5A7N2
385	350	257	250	355	7.5/0.4/7.9	CH62	LCX385A0-5A7N2
416	378	277	250	355	8.0/0.4/8.4	CH62	LCX416A0-5A7N2
460	418	307	300	400	8.5/0.4/8.9	CH62	LCX460A0-5A7N2
502	456	335	355	450	10.0/0.5/10.5	CH62	LCX502A0-5A7N2
590	536	393	400	560	10.0/0.5/10.5	CH63	LCX590A0-5A7N2
650	591	433	450	600	13.5/0.7/14.2	CH63	LCX650A0-5A7N2
750	682	500	500	700	16.0/0.8/16.8	CH63	LCX750A0-5A7N2
820	745	547	560	800	16.0/0.8/16.8	CH64	LCX820A0-5A7N2
920	836	613	650	850	18.0/0.9/18.9	CH64	LCX920A0-5A7N2
1030	936	687	700	1000	19.0/1.0/20.0	CH64	LCXH10A0-5A7N2
1180	1073	787	800	1100	21.0/1.0/20.1	CH64	LCXH11A0-5A7N2
1300	1182	867	900	1200	27.0/1.4/28.4	CH64	LCXH13A0-5A7N2
1500	1364	1000	1050	1400	32.0/1.6/33.6	CH64	LCXH15A0-5A7N2
1700	1545	1133	1150	1550	N/A	CH64	LCXH17A0-5A7N2
1850	1682	1233	1250	1650	34.2/1.8/36.0	2*CH64	LCXH18A0-5A7N2
2120	1927	1413	1450	1900	37.8/2.0/39.8	2*CH64	LCXH21A0-5A7N2
2340	2127	1560	1600	2100	48.6/2.5/51.1	2*CH64	LCXH23A0-5A7N2
2700	2455	1800	1850	2450	57.6/3.0/60.6	2*CH64	LCXH27A0-5A7N2
3100	2818	2066	2150	2800	N/A	2*CH64	LCXH31A0-5A7N2

## Options

### 9000X Series Option Board Kits

The 9000X Series drives can accommodate a wide selection of expander and adapter option boards to customize the drive for your application needs. The drive's control unit is designed to accept a total of five option boards.

The 9000X Series factory installed standard board configuration includes an A9 I/O board and an A2 relay output board, which are installed in slots A and B.

#### Option Boards

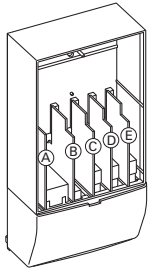

#### Option Board Kits

Option Kit Description <sup>①</sup>	Allowed Slot Locations <sup>②</sup>	Field Installed Catalog Number	Factory Installed Option Designator	SVX Ready Programs						
				Basic	Local/Remote	Standard	MSS	PID	Multi-P.	PFC
<b>Standard I/O Cards</b>										
2 RO (NC-NO)	B	<b>OPTA2</b>	—	■	■	■	■	■	■	■
6 DI, 1 DO, 2 AI, 1 AO, 1 +10 Vdc ref, 2 ext +24 Vdc/EXT +24 Vdc	A	<b>OPTA9</b>	—	■	■	■	■	■	■	■
<b>Extended I/O Cards</b>										
2 RO, therm	B	<b>OPTA3</b>	<b>A3</b>	—	■	■	■	■	■	■
Encoder low Volt +5 V/15 V/24 V	C	<b>OPTA4</b>	<b>A4</b>	—	■	■	■	■	■	■
Encoder high Volt +15 V/24 V	C	<b>OPTA5</b>	<b>A5</b>	—	■	■	■	■	■	■
Dual encoder +15 V/24 V	C	<b>OPTA7</b>	<b>A7</b>	—	■	■	■	■	■	■
6 DI, 1 DO, 2 AI, 1 AO	A	<b>OPTA8</b>	<b>A8</b>	—	■	■	■	■	■	■
3 DI (encoder 10–24 V), out +15 V/+24 V, 2 DO (pulse+direction)—SPX only	C	<b>OPTAE</b>	<b>AE</b>	■	■	■	■	■	■	■
6 DI, 1 ext +24 Vdc/EXT +24 Vdc	B, C, <b>D</b> , E	<b>OPTB1</b>	<b>B1</b>	—	—	—	—	—	■	■
1 RO (NC-NO), 1 RO (NO), 1 therm	B, C, <b>D</b> , E	<b>OPTB2</b>	<b>B2</b>	—	—	—	—	—	■	■
1 AI (mA isolated), 2 AO (mA isolated), 1 ext +24 Vdc/EXT +24 Vdc	B, C, <b>D</b> , E	<b>OPTB4</b>	<b>B4</b>	—	■	■	■	■	■	■
3 RO (NO)	B, C, <b>D</b> , E	<b>OPTB5</b>	<b>B5</b>	—	—	—	—	—	■	■
1 ext +24 Vdc/EXT +24 Vdc, 3 Pt100	B, C, <b>D</b> , E	<b>OPTB8</b>	<b>B8</b>	—	—	—	—	—	—	—
1 RO (NO), 5 DI 42–240 Vac input	B, C, <b>D</b> , E	<b>OPTB9</b>	<b>B9</b>	—	—	—	—	—	■	■
SPI, absolute encoder	C	<b>OPTBB</b>	<b>BB</b>	—	—	—	—	—	—	—
<b>Communication Cards <sup>③</sup></b>										
Modbus	<b>D</b> , E	<b>OPTC2</b>	<b>C2</b>	■	■	■	■	■	■	■
Johnson Controls N2	<b>D</b> , E	<b>OPTC2</b>	<b>CA</b>	—	—	—	—	—	—	—
PROFIBUS DP	<b>D</b> , E	<b>OPTC3</b>	<b>C3</b>	■	■	■	■	■	■	■
LonWorks	<b>D</b> , E	<b>OPTC4</b>	<b>C4</b>	■	■	■	■	■	■	■
PROFIBUS DP (D9 connector)	<b>D</b> , E	<b>OPTC5</b>	<b>C5</b>	■	■	■	■	■	■	■
CANopen (slave)	<b>D</b> , E	<b>OPTC6</b>	<b>C6</b>	■	■	■	■	■	■	■
DeviceNet	<b>D</b> , E	<b>OPTC7</b>	<b>C7</b>	■	■	■	■	■	■	■
Modbus (D9 Type connector)	<b>D</b> , E	<b>OPTC8</b>	<b>C8</b>	■	■	■	■	■	■	■
Modbus TCP	<b>D</b> , E	<b>OPTC1</b>	<b>C1</b>	■	■	■	■	■	■	■
Adapter—SPX only	<b>D</b> , E	<b>OPTD1</b>	<b>D1</b>	■	■	■	■	■	■	■
Adapter—SPX only	<b>D</b> , E	<b>OPTD2V</b>	<b>D2</b>	■	■	■	■	■	■	■
RS-232 with D9 connection	<b>D</b> , E	<b>OPTD3</b>	<b>D3</b>	■	■	■	■	■	■	■
<b>Keypad</b>										
9000X Series standard keypad	—	<b>KEYPAD-STD</b>	—	—	—	—	—	—	—	■
9000X Series remote mount keypad unit (keypad not included, includes 10 ft cable, keypad holder, mounting hardware)	—	<b>OPTRMT-KIT-9000X</b>	—	—	—	—	—	—	—	—

#### Notes

<sup>①</sup> AI = Analog Input; AO = Analog Output, DI = Digital Input, DO = Digital Output, RO = Relay Output

<sup>②</sup> Option card must be installed in one of the slots listed for that card. Slot indicated in bold is the preferred location.

<sup>③</sup> OPTC2 is a multi-protocol option card.

## Technical Data and Specifications

## 2

### LCX Products

Description	Specification
<b>General Specifications</b>	
Line voltage	400 to 500 Vac; 525 to 690 Vac; (–10% to 10%) 465 to 800 Vdc; 640 to 1100 Vdc; (–0 to 0%)
Frequency	50/60 Hz
Line voltage variation	–10% to 10%
Input frequency variation	45–66 Hz
Continuous output current	Rated current at incoming cooling liquid temperature of 30 °C
Output frequency	0–320 Hz
Drive efficiency	>95%
Power factor (displacement)	0.96
Liquid coolant pressure	87 psi (6 bar) maximum
Liquid coolant flow rate	1.3 to 7.9 gal./min. (5 to 30 liter/min.) minimum depending on drive size
Liquid coolant fittings	Standard quick connect, NPT
Operating ambient temperature	–10/50 °C
Storage temperature	–40/70 °C
Humidity	95% maximum (non-condensing)
Altitude	3300 ft (1000 m) maximum without derating
Enclosure	IP00
Warranty	Standard terms, 3 years with certified start-up
<b>Mains Connection</b>	
Input voltage ( $V_{in}$ )	400–500 Vac; 525–690 Vac; (–10%–10%) 465–800 Vdc; 640–1100 Vdc; (–0–0%)
Input frequency ( $f_{in}$ )	45–66 Hz
Connection to mains	Once per minute or less (normal case)
<b>Motor Connection</b>	
Output voltage	0– $V_{in}$
Continuous output current	Rated current at nominal inflow cooling water temperature of 30 °C; Overload 2 sec./20 sec.
Starting current	Rated current at 2 sec./20 sec. if output frequency <30 Hz and temperature of heatsink <149 °F (65 °C)
Output frequency	0–320 Hz (standard); 7200 Hz (special software)
Frequency resolution	Application dependent
<b>Control Characteristics</b>	
Control method	Frequency control (V/f) Open loop: Sensorless vector control Closed loop: Frequency control Closed loop: Vector control
Switching frequency 480 V ①	Adjustable with parameter 2.6.9 Up to and including 61-Amp size: 1–16 kHz (factory default, 10 kHz) From 72-Amp size: 1–12 kHz (factory default, 3.6 kHz)
575 V ①	1–6 kHz (factory default, 1.5 kHz)
Frequency reference	Analog input: resolution 0.1% (10 bits); accuracy ±1% Panel reference: resolution 0.01 Hz
Field weakening point	30–320 Hz
Acceleration time	0.1–3000 seconds
Deceleration time	0.1–3000 seconds
Braking torque	DC brake: 30% x $T_n$ (without brake option)

Description	Specification
<b>Ambient Conditions</b>	
Ambient operating temperature	14 °F (–10 °C), no frost to 122 °F (50 °C) at $I_{th}$ 122 to 158 °F (50 to 70 °C), derating required
Storage temperature	–40 °F to 158 °F (–40 to 70 °C) No liquid in heatsink under 32 °F (0 °C)
Relative humidity	5–96% RH, noncondensing, no dripping water
Air quality	Chemical vapors: IEC 721-3-3, unit in operation, class 3C2 Mechanical particles: IEC 721-3-3, unit in operation, class 3S2 (no conductive dust allowed); No corrosive gases
Altitude	Up to 1,000 m: 100% load capacity (no derating) Above 1,000 m: Derating of 1% per each 100 m required
Vibration	EN 50178, EN 60068-2-6; 5–150 Hz Displacement amplitude: 0.25 mm (peak) at 3–31 Hz Max. acceleration amplitude: 1G at 31–150 Hz
Shock	EN 50178, EN 60068-2-27, UPS drop test (for applicable UPS weights) Storage and shipping: Max. 15 g, 11 ms (in package)
Enclosure class	IP00 open frame standard in entire kW/hp range
<b>EMC</b>	
Immunity	Fulfills all EMC immunity requirements
Emissions	EMC level N; EMC level T for IT networks
<b>Safety</b>	
Approvals	EN 50178, EN 60204-1, CE, UL, CUL, FI, GOST R, IEC 61800-5 (See unit nameplate for more detailed approvals.)
<b>Control Connections</b>	
Analog input voltage	0 to +10 V, $R_i$ = 200 kohm (–10 V to +10 V joystick control) Resolution 0.1%; accuracy ±1%
Analog input current	0(4)–20 mA, $R_i$ = 250 ohm differential
Digital inputs	6 positive or negative logic; 18–24 Vdc
Auxiliary voltage	+24 V, ±15%, max. 250 mA
Output reference voltage	+10 V, +3%, max. load 10 mA
Analog output	0(4)–20 mA, $R_i$ max. 500 ohm Resolution 10 bits; accuracy ±2%
Digital outputs	Open collector output, 50 mA/48V
Relay outputs	Two programmable change-over relay outputs Switching capacity: 24 Vdc/8 A, 250 Vac/8 A, 125 Vdc/0.4 A Min. switching load: 5 V/10 mA

#### Note

① Derating required if higher switching frequency than the default is used.

## LCX Products, continued

Description	Specification
<b>Protections</b>	
Overvoltage protection	
480 V	911 V
575 V	1200 V
Undervoltage protection	
480 V	333 V
575 V	461 V
Ground fault protection	In case of ground fault in motor or motor cable, only the drive is protected
Mains supervision	Trips if any of the input phases are missing (drives only)
Motor phase supervision	Trips if any of the output phases are missing
Unit overtemperature protection	
Alarm limit	149 °F (65 °C) for heatsink, 158 °F (70 °C) for circuit boards
Trip limit	158 °F (70 °C) for heatsink, 185 °F (85 °C) for circuit boards

Description	Specification
<b>Protections, continued</b>	
Overcurrent protection	Yes
Motor overload protection	Yes
Motor stall protection	Yes
Motor underload protection	Yes
Short-circuit protection	Yes (+24 V and +10 V reference voltages)
<b>Liquid Cooling</b>	
Allowed cooling agents	Drinking water Water-glycol mixture
Temperature of cooling agent	32 to 86 °F (0 to 30 °C) at $I_{th}$ for input; 86 to 149 °F (30 to 65 °C) Max. temperature rise during circulation: 9 °F (5 °C), no condensation allowed
System max. working pressure	87 psi (6 bar)
System max. peak pressure	580 psi (40 bar)
Pressure loss (at nominal flow)	Varies according to size

## Wiring Diagrams

## Cooling System Diagrams

## Example of a Typical Cooling System

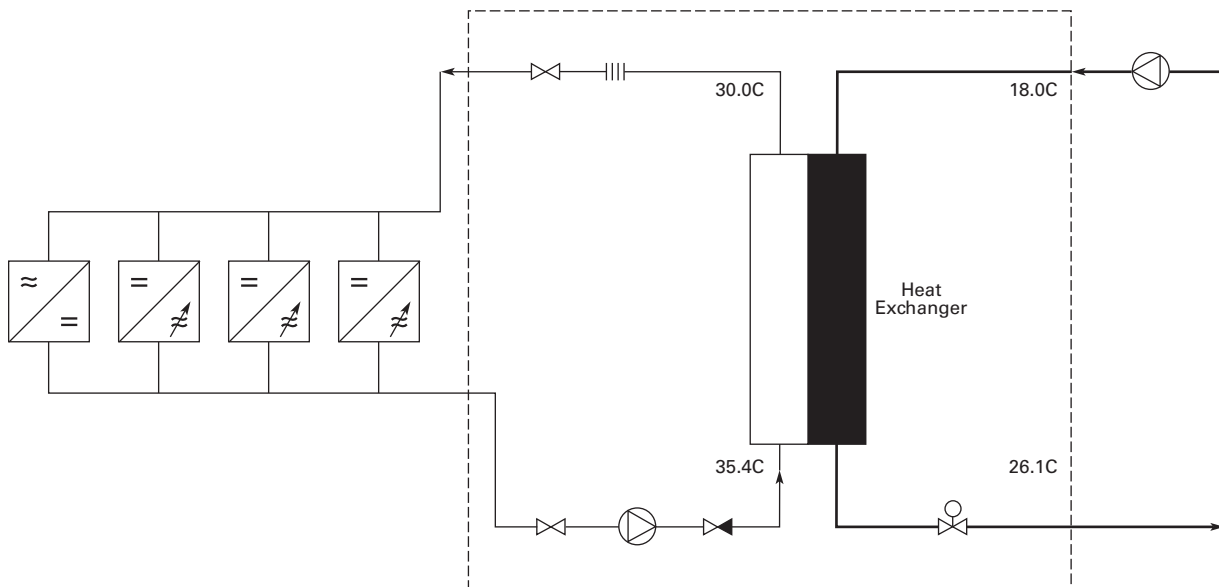

# 2.12

## Adjustable Frequency Drives

### LCX Liquid Cooled Drives

#### Example PI-Diagram of a Typical Cooling System and Connections

2

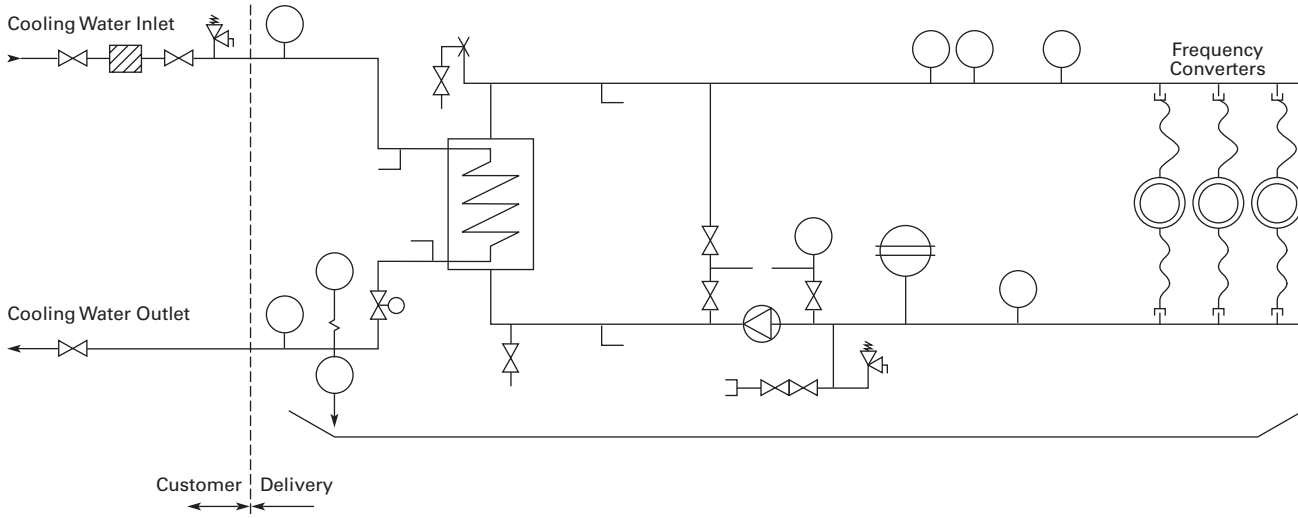

#### I/O Board Diagrams

##### A9 Option Board Control Wiring

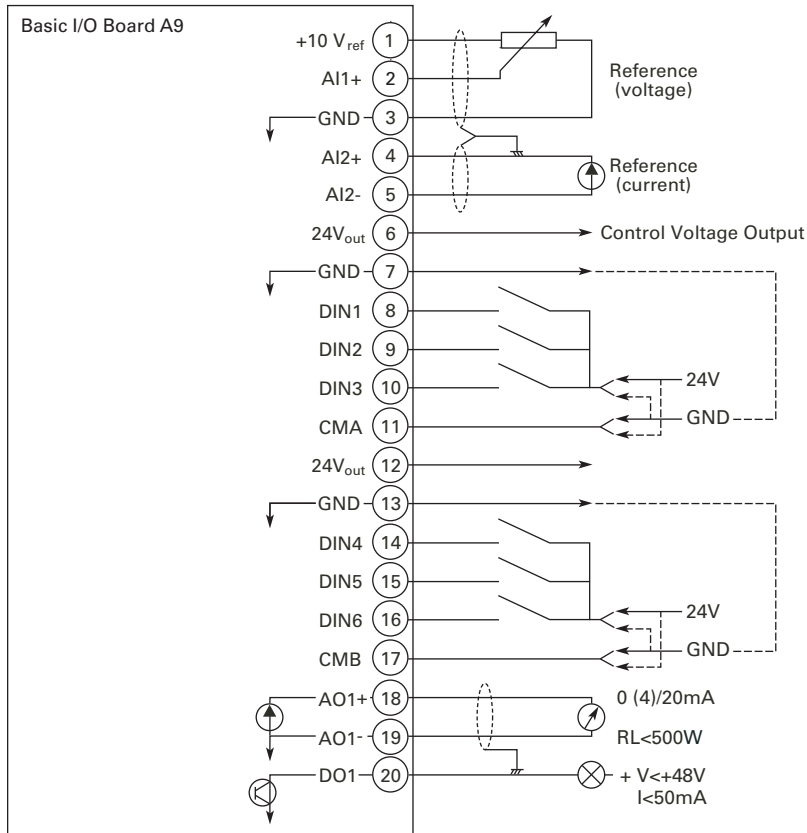

Dotted lines indicate the connections for inverted signals

## A2 Option Board Wiring

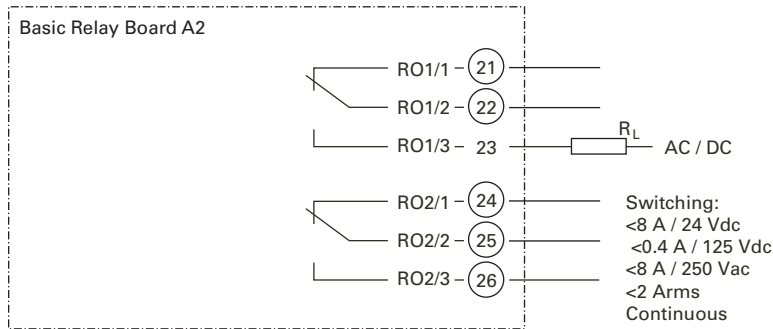

## Dimensions

Approximate Dimensions in Inches (mm)

## LCX Drives

## Chassis Size, CH3

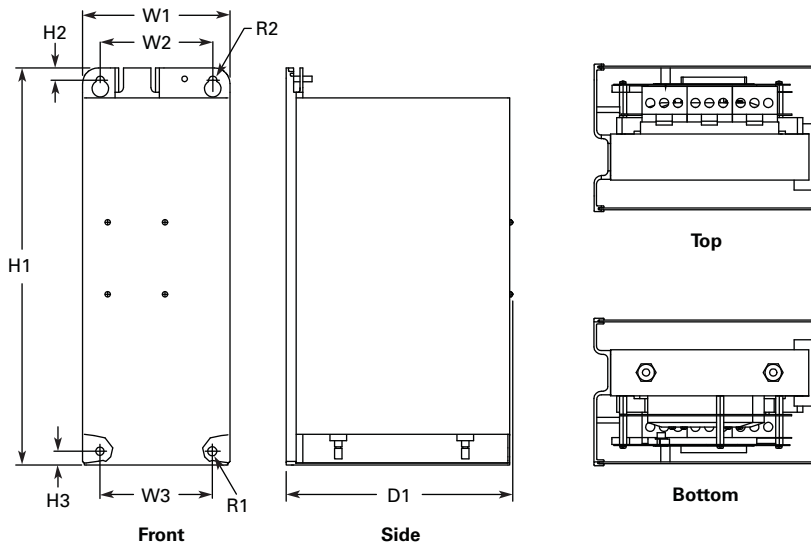

Voltage	Amps	H1	H2	H3	D1	W1	W2	W3	R1 Dia.	R2 Dia.	Weight Lbs (kg)
380-500 Vac	16-61	16.97 (431.0)	0.53 (13.5)	0.59 (15.0)	9.69 (246.0)	6.30 (160.0)	4.80 (122.0)	4.80 (122.0)	0.39 (10.0)	0.35 (9.0)	66 (30)

# 2.12

## Adjustable Frequency Drives

### LCX Liquid Cooled Drives

Approximate Dimensions in Inches (mm)

#### Chassis Size, CH4

2

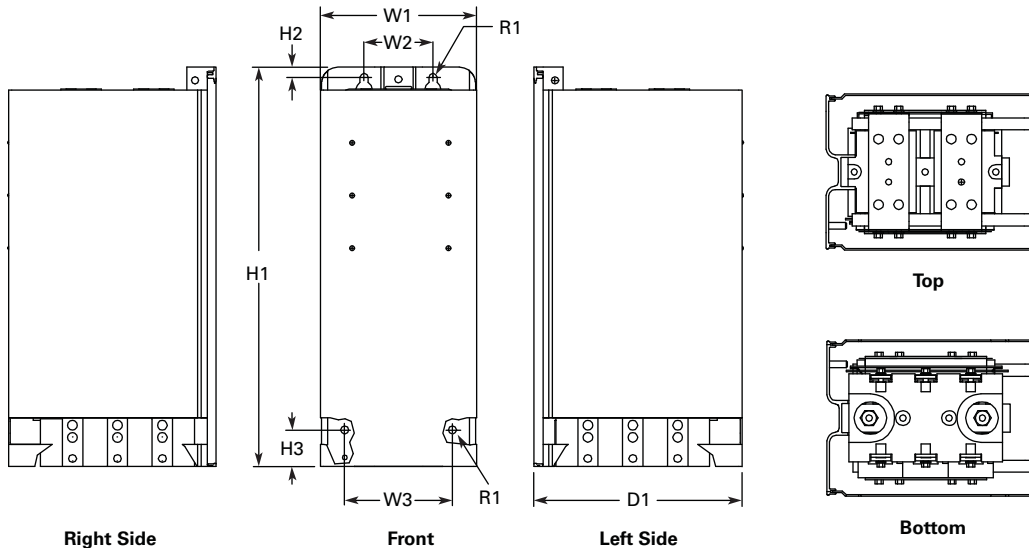

Voltage	Amps	H1	H2	H3	D1	W1	W2	W3	R1 Dia.	R2 Dia.	Weight Lbs (kg)
380–500 Vac	72–140	19.41 (493.0)	0.49 (12.5)	1.77 (45.0)	10.14 (257.5)	7.60 (193.0)	3.35 (85.0)	5.24 (133.0)	0.39 (10.0)	—	77 (35)

#### Chassis Size, CH5

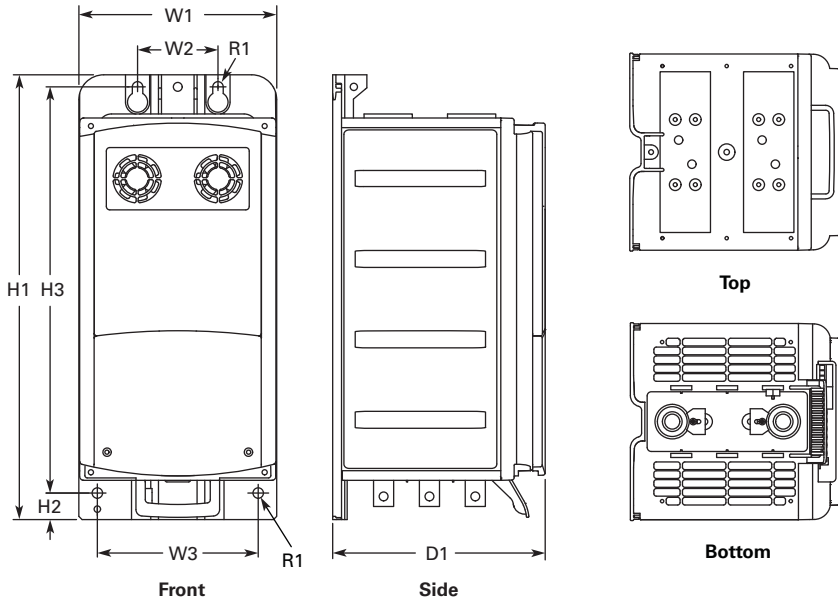

Voltage	Amps	H1	H2	H3	D1	W1	W2	W3	R1 Dia.	R2 Dia.	Weight Lbs (kg)
380–500 Vac	168–261	21.77 (553.0)	1.30 (33.0)	19.88 (505.0)	10.39 (264.0)	9.69 (246)	3.94 (100.0)	7.87 (200.0)	0.51 (13.0)	—	88 (40)

Approximate Dimensions in Inches (mm)

## Chassis Size, CH61

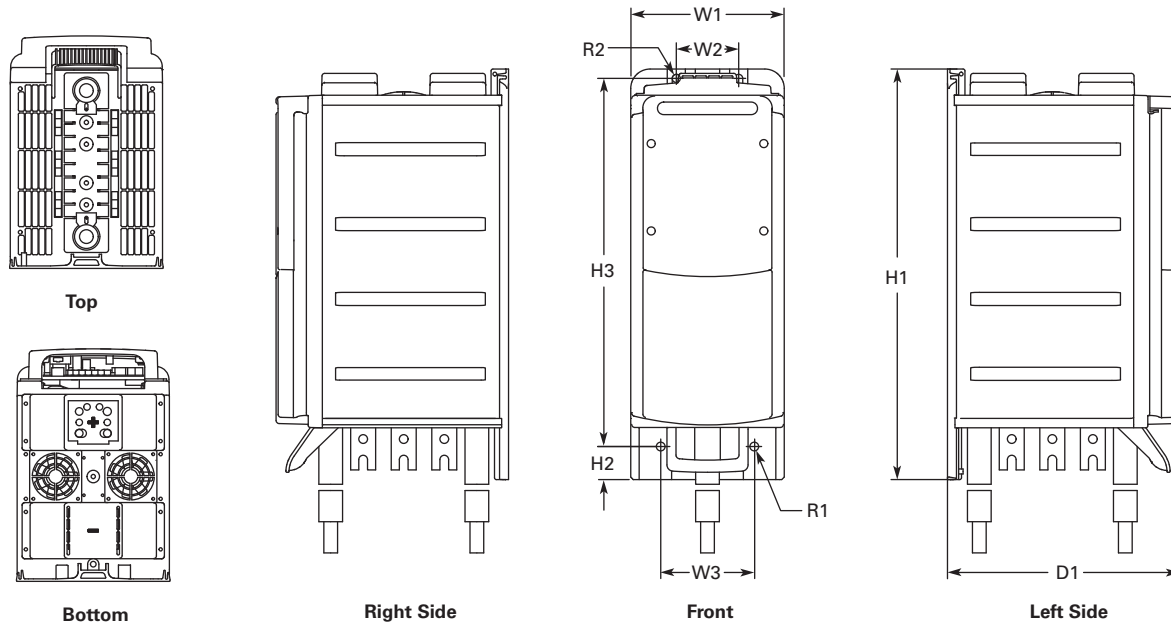

Voltage	Amps	H1	H2	H3	D1	W1	W2	W3	R1 Dia.	R2 Dia.	Weight Lbs (kg)
380–500 Vac	300–385	25.91 (658.0)	2.09 (53.0)	23.23 (590.0)	14.69 (373.0)	9.69 (246.0)	3.94 (100.0)	5.91 (150.0)	0.55 (14.0)	0.51 (13.0)	121 (55)
525–690 Vac	170–208										

## Liquid-Cooled Inverter—Chassis Size, CH62

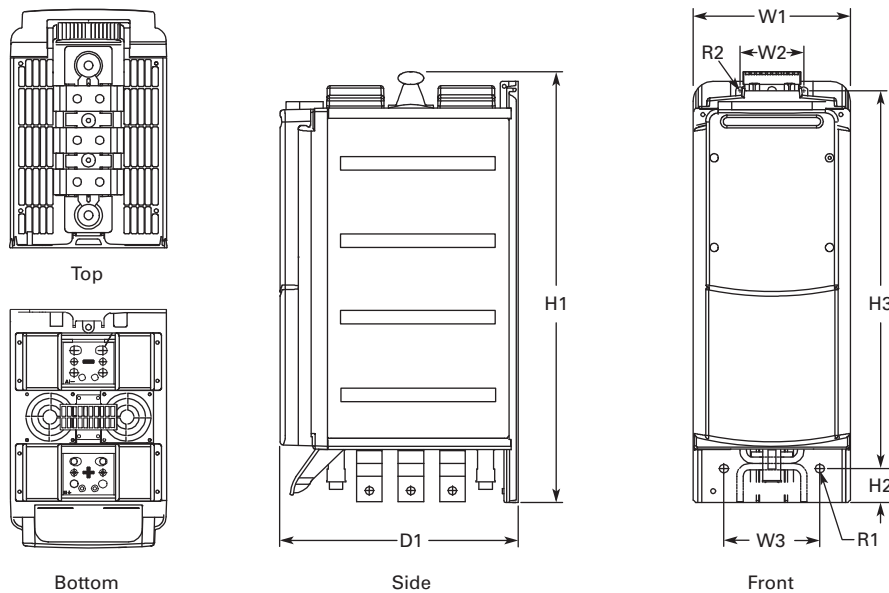

Voltage	Amps	H1	H2	H3	D1	W1	W2	W3	R1 Dia.	R2 Dia.
540–675 Vdc	460–730	26.50 (673)	2.0 (53)	23.23 (590)	14.69 (373)	9.69 (246)	3.94 (100)	5.91 (150)	0.55 (14)	0.51 (13)
710–930 Vdc	325–502									

# 2.12

## Adjustable Frequency Drives

### LCX Liquid Cooled Drives

Approximate Dimensions in Inches (mm)

2

#### Chassis Size, CH63

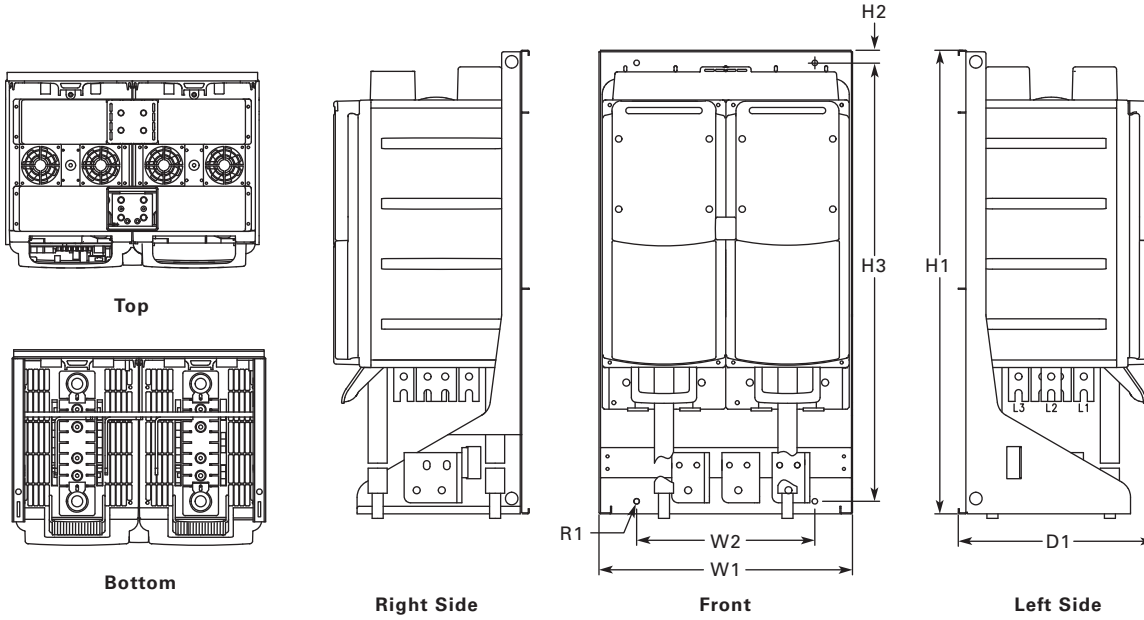

Voltage	Amps	H1	H2	H3	D1	W1	W2	R1 Dia.	Weight Lbs (kg)
380–500 Vac	820–1030	36.36 (923.5)	0.91 (23.0)	34.39 (873.5)	15.35 (390.0)	19.88 (505.0)	13.98 (355.0)	0.43 (11.0)	264 (120)
525–690 Vac	590–750								

Approximate Dimensions in Inches (mm)

### Liquid-Cooled Inverter with Mounting Bracket, Chassis Size CH64, IP90

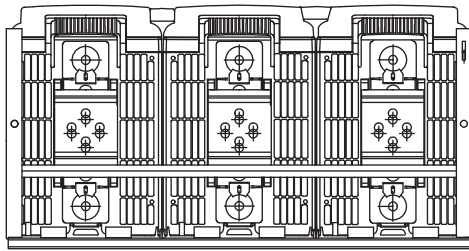

Bottom

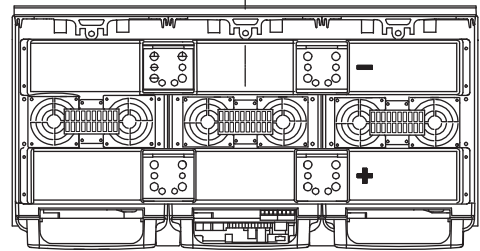

Top

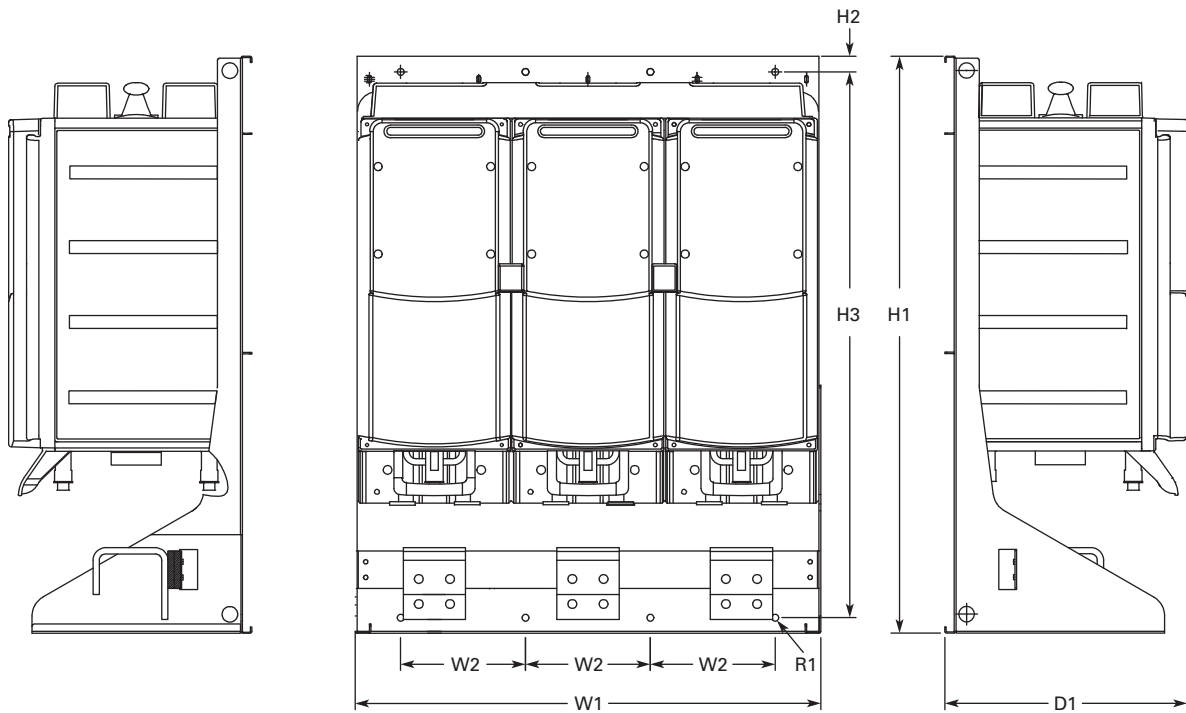

Right Side

Front

Left Side

Voltage	Amps	H1	H2	H3	D1	W1	W2	R1 Dia.
540–675 Vdc	1370–4140	36.38	1.03	34.37	15.35	29.37	7.87	0.43
710–930 Vdc	820–3100	(924)	(26)	(873)	(390)	(746)	(200)	(11)

# 2.12

## Adjustable Frequency Drives

### LCX Liquid Cooled Drives

Approximate Dimensions in Inches (mm)

#### Chassis Size, CH72

2

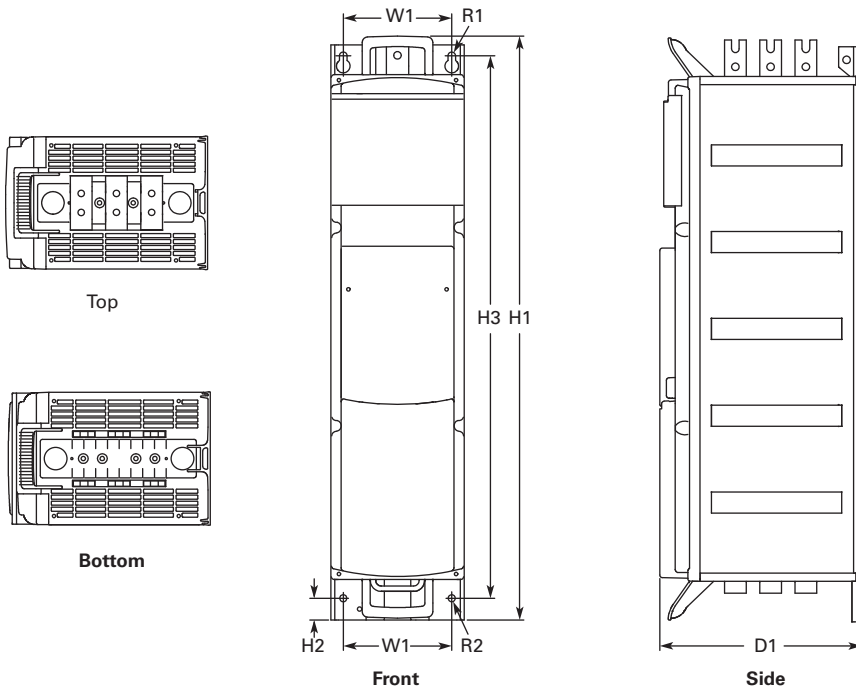

Voltage	Amps	H1	H2	H3	D1	W1	R1 Dia.	R2 Dia.	Weight Lbs (kg)
380–500 Vac	460–730	42.38	1.57	39.37	14.65	7.87	0.55	0.51	198 (90)
525–690 Vac	261–502	(1076.5)	(40.0)	(1000.0)	(372.0)	(200.0)	(14.0)	(13.0)	

Approximate Dimensions in Inches (mm)

### Chassis Size, CH74

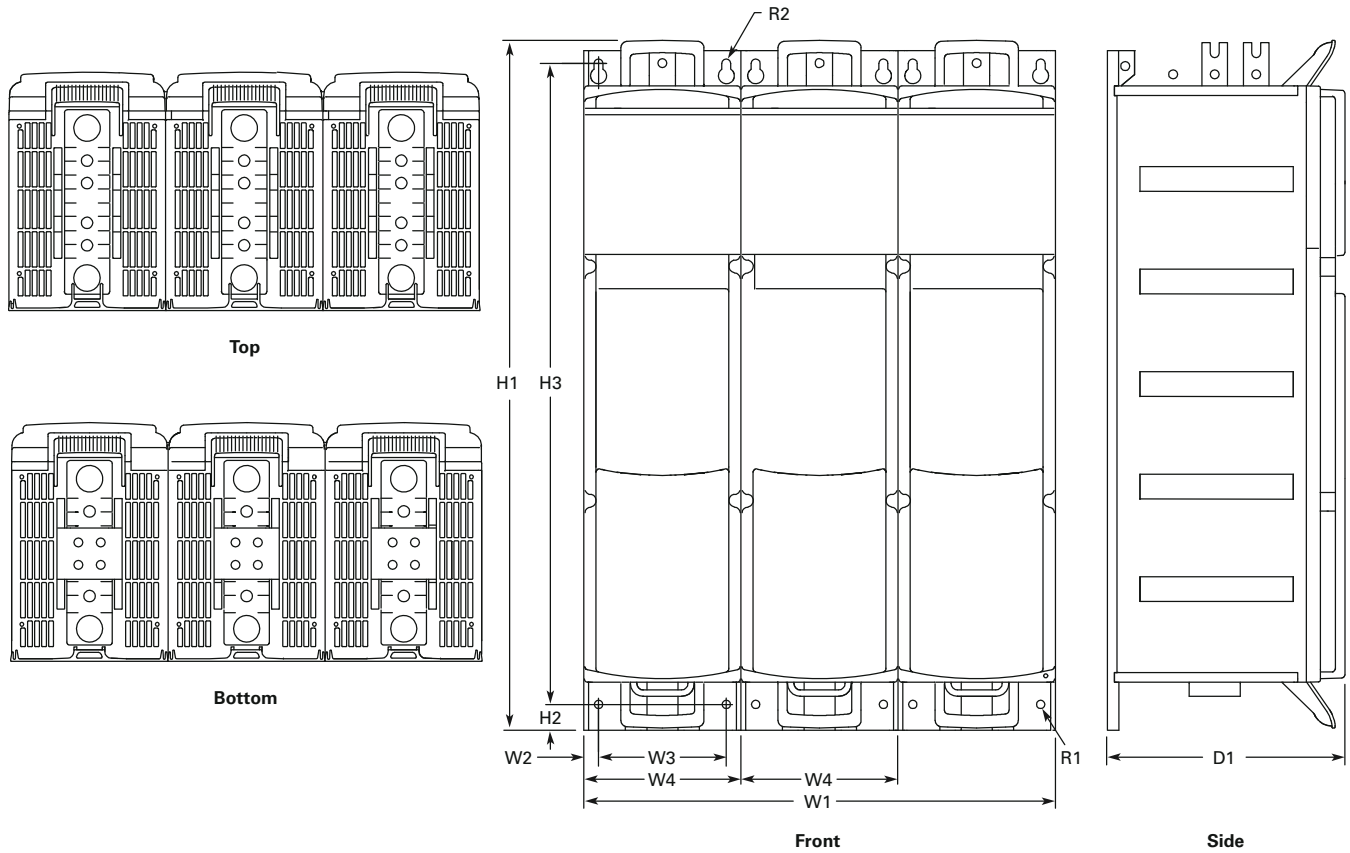

Voltage	Amps	H1	H2	H3	D1	W1	W2	W3	W4	R1 Dia.	R2 Dia.	Weight Lbs (kg)
380–500 Vac	1370–2300	42.38	1.57	39.37	14.65	29.06	0.91	7.87	9.69	0.51	0.55	617 (280)
525–690 Vac	820–1500	(1076.5)	(40.0)	(1000.0)	(372.0)	(738.0)	(23.0)	(200.0)	(246)	(13.0)	(14.0)	

### Control Unit

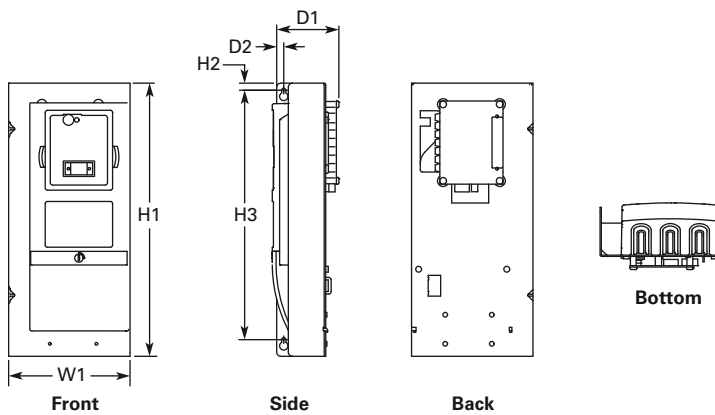

H1	H2	H3	D1	D2	W1
12.93	0.33	11.81	2.95	0.33	5.75
(328.5)	(8.5)	(300.0)	(75.0)	(8.5)	(146.0)